

Types of Lasers

Since the discovery of the laser, literally thousands of types of lasers have been discovered. As Arthur Shawlow is purported to have said, "Hit it hard enough and anything will lase." However, only a relative few of these lasers have found broadly based, practical applications.

Lasers can be broadly classified into four categories: gas discharge lasers, semiconductor diode lasers, optically pumped lasers, and "other," a category which includes chemical lasers, gas-dynamics lasers, x-ray lasers, combustion lasers, and others developed primarily for military applications. These lasers are not discussed further here.

GAS-DISCHARGE LASERS

In principle, gas-discharge lasers are inherently simple—fill a container with gas, put some mirrors around it, and strike a discharge. In practice, they are much more complex because the gas mix, discharge parameters, and container configuration must be specifically and carefully designed to create the proper conditions for a population inversion. Furthermore, careful consideration must be given to how the discharge will react with its container and with the laser optics. Finally, since the temperature of the gas can affect the discharge conditions, questions of cooling must be addressed.

Figure 10.17 below shows a cutaway of a helium neon laser, one of the simplest gas-discharge lasers. An electrical discharge is struck between the anode and cathode. The laser bore confines the discharge, creating the current densities needed to create the inversion. In this example, the laser mirrors are mounted to the ends of the tube and are effectively part of the gas container. In other cases, the mirrors are external to the container,

and light enters and exits the chamber through Brewster's windows or extremely low-loss antireflection-coated normal windows. Because most gas-discharge lasers are operated at extremely low pressures, a getter is needed to remove the impurities generated by outgassing in the walls of the container or by erosion of the electrodes and bore caused by the discharge. The Brewster's window is used to linearly polarize the output of the laser.

The most common types of gas-discharge lasers are helium neon lasers, helium cadmium lasers (a metal-vapor laser), noble-gas ion lasers (argon, krypton), carbon-dioxide lasers, and the excimer-laser family. Each of these will be discussed briefly below.

Helium Neon Lasers

The helium neon (HeNe) laser, shown in figure 10.17, the second laser to be discovered, was the first to be used in volume applications. Today, millions of these lasers are in the field, and only semiconductor diode lasers are sold in greater quantity.

The HeNe laser operates in a high-voltage (kV), low-current (mA) glow discharge. Its most familiar output wavelength is 633 nm (red), but HeNe lasers are also available with output at 543 nm (green), 594 nm (yellow), 612 nm (orange), and 1523 nm (near infrared). Output power is low, ranging from a few tenths to tens of milliwatts, depending on the wavelength and size of the laser tube.

Helium is the major constituent (85 percent) of the gas mixture, but it is the neon component that is the actual lasing medium. The glow discharge pumps the helium atoms to an excited state that closely matches the upper energy levels of the neon atoms. This energy is then transferred to

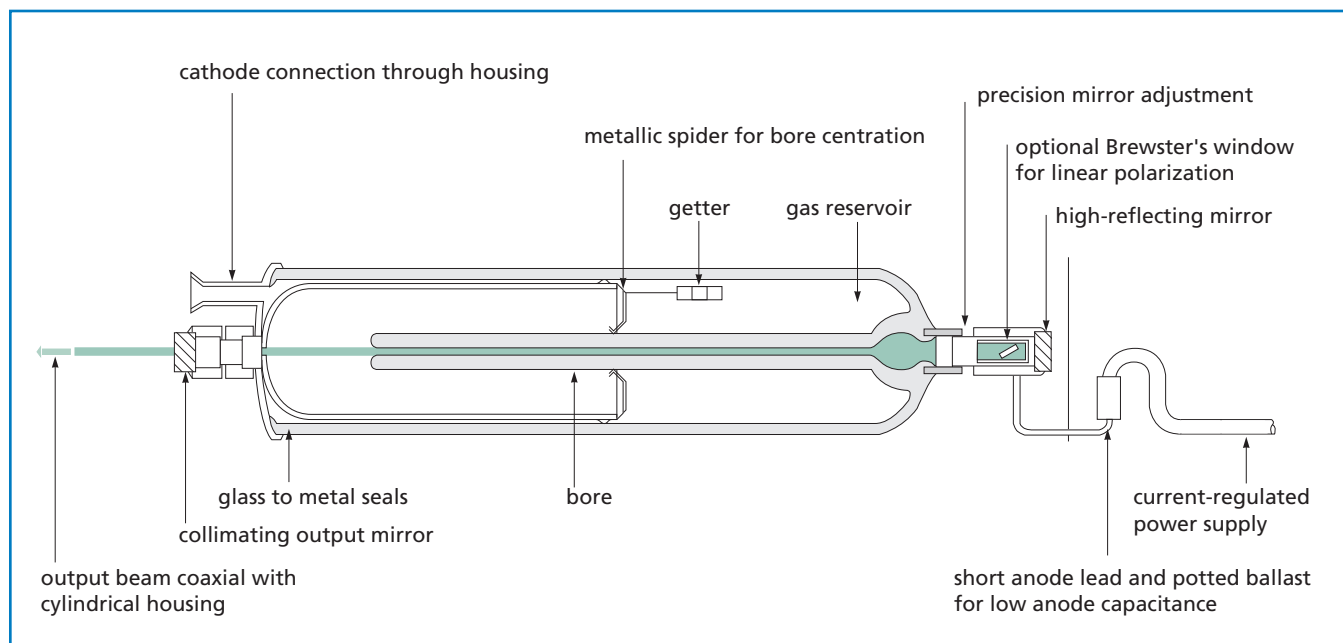

Figure 10.17 Typical HeNe laser construction

the neon atoms via collisions of the second kind (i.e., exciting the neon to a higher energy level as opposed to transferring the energy as kinetic motion). One characteristic of the glow discharge is its negative impedance (i.e., increasing the voltage decreases the current); consequently, to function with a standard current-regulated power supply, a ballast resistor must be used in series with the laser to make the overall impedance positive.

The popularity (and longevity) of the HeNe laser is based on five factors: they are (relative to other lasers) small and compact; they have the best inherent beam quality of any laser, producing a virtually pure single transverse mode beam ($M^2 < 1.05$); they are extremely long lived, with many examples of an operating life of 50,000 hours or more; they generate relatively little heat and are convection cooled easily in OEM packages; and they have a relatively low acquisition and operating cost.

Helium Cadmium Lasers

Helium cadmium (HeCd) lasers are, in many respects, similar to the HeNe laser with the exception that cadmium metal, the lasing medium, is solid at room temperature. The HeCd laser is a relatively economical, cw source for violet (442 nm) and ultraviolet (325 nm) output. Because of its excellent wavelength match to photopolymer and film sensitivity ranges, it is used extensively for three-dimensional stereolithography and holographic applications.

As mentioned above, cadmium, a metal, is solid at room temperature. For lasing to occur, the metal must be evaporated from a reservoir, as shown in figure 10.18, and then the vapor must be distributed uniformly down the laser bore. This is accomplished through a process called electrophoresis. Because cadmium will plate out on a cool surface, extreme care must be taken in the design of the laser to contain the cadmium and to protect the optics and windows from contamination, since even a slight film will introduce sufficient losses to stop lasing. The end of life usually occurs when cadmium is depleted from its reservoir.

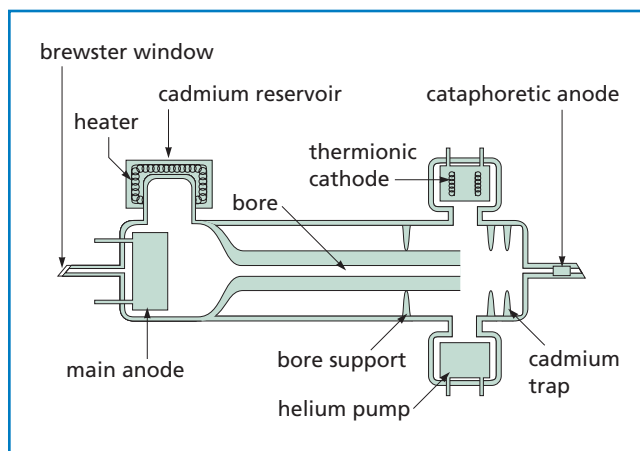

Figure 10.18 Construction of a HeCd laser

Noble-Gas Ion Lasers

The noble-gas ion lasers (argon-ion and krypton-ion), have been the mainstay of applications requiring high cw power in the visible, ultraviolet, and near-infrared spectral regions. High-power water-cooled systems can be found in research laboratories around the world; lower-power air-cooled systems are used in a wide variety of OEM applications. Argon-ion lasers are available with output up to 7 W in the ultraviolet (333–354 nm) and 25 W or more in the visible regions (454–515 nm), with primary output at 488 nm (blue) and 514 nm (green). Krypton-ion lasers have their primary output at 568 nm (yellow), 647 nm (red), and 752 nm (near infrared). Mixed-gas lasers combine both argon and krypton to produce lasers with a wider spectral coverage.

Unlike the HeNe laser, ion lasers operate with a high-intensity low-pressure arc discharge (low voltage, high current). A 20-W visible laser will require 10 kW or more power input, virtually all of which is deposited in the laser head as heat which must be removed from the system by some cooling mechanism. Furthermore, the current densities in the bore, which can be as high as 10^5 A/cm^2 , place large stresses on the bore materials.

Ion lasers can be broken into two groups: high-power (1–20+ W) water-cooled lasers and low-power air-cooled lasers. Both are shown schematically in figure 10.19.

The main features of both lasers are the same. Both use a coiled, directly-heated dispenser cathode to supply the current; both have a gas return path that counteracts gas pumping (non-uniform gas pressure throughout the length of the tube caused by the charged particles moving toward the electrodes).

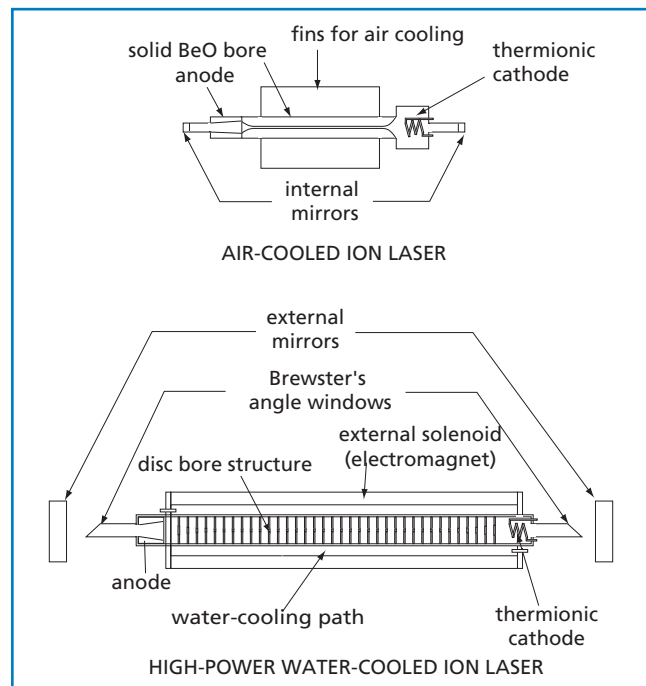

Figure 10.19 Air-cooled and water-cooled ion lasers

The bore of an air-cooled system is always made of beryllium oxide (BeO), a ceramic known for its ability to conduct heat. A fin structure is attached to the outside of the ceramic bore, and a blower removes the generated heat, typically less than 1 kW.

Water-cooled systems are available with either BeO bores or a construction wherein tungsten discs are attached to a thin-walled ceramic tube surrounded by a water jacket. The heat from the discs is conducted through the walls of the tube to the surrounding water. The entire bore structure is surrounded by a solenoid electromagnet, which compresses the discharge to increase current density and minimize bore erosion.

The main life-limiting factors in ion lasers are cathode depletion and gas consumption. The intense discharge drives atoms into the walls of the discharge tube where they are lost to the discharge. Over time the tube pressure will decrease, causing the discharge to become unstable. This is particularly a problem with krypton-ion lasers. Water-cooled systems typically have some refill mechanism to keep the pressure constant. Air-cooled systems typically do not, limiting their practical operating life to approximately 5000 operating hours.

Carbon Dioxide Lasers

Because of their ability to produce very high power with relative efficiency, carbon dioxide (CO₂) lasers are used primarily for materials-processing applications. The standard output of these lasers is at 10.6 μm, and output power can range from less than 1 W to more than 10 kW.

Unlike atomic lasers, CO₂ lasers work with molecular transitions (vibrational and rotational states) which lie at low enough energy levels that they can be populated thermally, and an increase in the gas temperature, caused by the discharge, will cause a decrease in the inversion level, reducing output power. To counter this effect, high-power cw CO₂ lasers use flowing gas technology to remove hot gas from the discharge region and replace it with cooled (or cooler) gas. With pulsed CO₂ lasers that use transverse excitation, the problem is even more severe, because, until the heated gas between the electrodes is cooled, a new discharge pulse cannot form properly.

A variety of types of CO₂ lasers are available. High-power pulsed and cw lasers typically use a transverse gas flow with fans which move the gas through a laminar-flow discharge region, into a cooling region, and back again (see figure 10.20). Low-power lasers most often use waveguide structures, coupled with radio-frequency excitation, to produce small, compact systems.

Excimer Lasers

The term excimer or “excited dimer” refers to a molecular complex of two atoms which is stable (bound) only in an electronically excited state. These lasers, which are available only as pulsed lasers, produce intense output in the ultraviolet and deep ultraviolet. The lasers in this family are XeFl (351 nm), XeCl (308 nm), KrF (248 nm), KrCl (222 nm), ArF (193 nm), and F₂ (157 nm). They are used extensively in photolithography, micromachining, and medical (refractive eye surgery) applications.

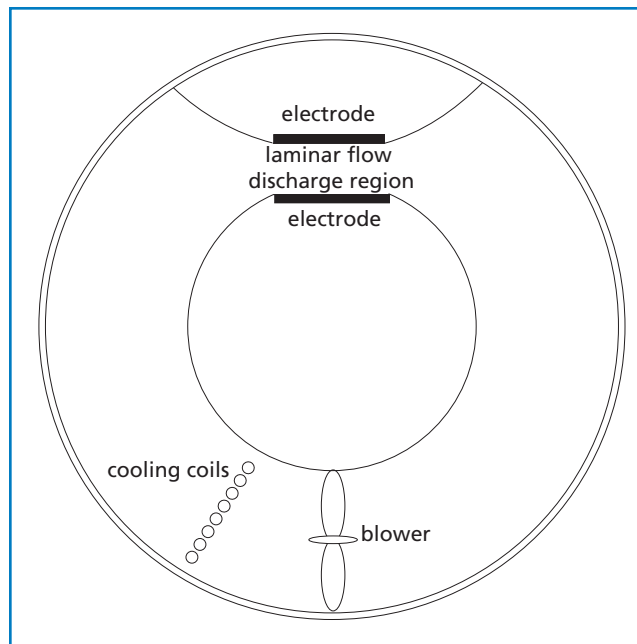

Figure 10.20 Schematics of transverse flow CO₂ laser system

At first glance, the construction of an excimer laser is very similar to that of a transverse-flow, pulsed CO₂ laser. However, the major difference is that the gases in the system are extremely corrosive and great care must be taken in the selection and passivation of materials to minimize their corrosive effects. A system built for CO₂ would fail in minutes, if not seconds.

The principal advantage of an excimer laser is its very short wavelength. The excimer output beam can be focused to a spot diameter that is approximately 40 times smaller than the CO₂ laser beam with the same beam quality. Furthermore, whereas the long CO₂ wavelength removes material thermally via evaporation (boiling off material), the excimer lasers with wavelengths near 200 nm remove material via ablation (breaking molecules apart), without any thermal damage to the surrounding material.

SEMICONDUCTOR DIODE LASERS

The means of generating optical gain in a diode laser, the recombination of injected holes and electrons (and consequent emission of photons) in a forward-biased semiconductor pn junction, represents the direct conversion of electricity to light. This is a very efficient process, and practical diode laser devices reach a 50-percent electrical-to-optical power conversion rate, at least an order of magnitude larger than most other lasers. Over the past 20 years, the trend has been one of a gradual replacement of other laser types by diode laser based-solutions, as the considerable challenges to engineering with diode lasers have been met. At the same

time the compactness and the low power consumption of diode lasers have enabled important new applications such as storing information in compact discs and DVDs, and the practical high-speed, broadband transmission of information over optical fibers, a central component of the Internet.

Construction of a double-heterostructure diode laser

In addition to a means to create optical gain, a laser requires a feedback mechanism, a pair of mirrors to repeatedly circulate the light through the gain medium to build up the resulting beam by stimulated emission. The stripe structures needed to make a laser diode chip are formed on a single crystal wafer using the standard photolithographic patterning techniques of the semiconductor industry. The substrate crystal axes are first oriented relative to the patterning such that, after fabrication, a natural cleavage plane is normal to the stripe direction, and cleaving both ends of the chip provides a pair of plane, aligned crystal surfaces that act as a Fabry-Perot resonator for optical feedback. These mirrors use either the Fresnel reflectivity of the facet (often sufficient because of the high gain of diode lasers), or they can be dielectric coated to other reflectivities. This might be desired, for instance, to protect against damage from the high irradiance at the facets. This geometry gives the familiar edge-emitting diode laser (see figure 10.21).

The semiconductor crystal must be defect free to avoid scattering of carriers and of light. To grow crystal layers without defects, commercial semiconductor lasers use III-V compounds, elements taken from those columns of the periodic table. These form varying alloys with the addition of dopants that can be lattice-matched to each other and to the initial crystal substrate. The band gap of the semiconductor chosen determines the lasing wavelength region. There are three main families: GaN-based lasers with UV-blue outputs, GaAs-based lasers with red-near infrared outputs, and InP-based lasers with infrared outputs. These base crystals are precisely doped with Ga, Al, In, As, and P to precisely control the band gap and index of refraction of the layers in the diode structure.

These compounds are direct band-gap semiconductors with efficient recombination of injected holes and electrons because no phonons (lattice vibrations) are required to conserve momentum in the recombination interaction. The injection layers surrounding the junction, the cladding layers, can be indirect band-gap semiconductors (where phonons are involved).

To make a planar waveguide that concentrates the light in the junction region (confinement between the top and bottom horizontal planes of the active region in figure 10.21), the cladding layers are made of an alloy of lower refractive index (larger band gap) than the active junction region. This is then termed a double-heterostructure (DH) laser. The output power of the laser is horizontally polarized because the reflectivity of the planar waveguide is higher for the polarization direction parallel to the junction plane. Because the junction region is thin for efficient recombination (typically $0.1 \mu\text{m}$), some light spreads into the cladding layers which are therefore made relatively thick (typically $1 \mu\text{m}$) for adequate light confinement.

Gain guiding and index guiding in diode lasers

To confine the light laterally (between planes perpendicular to the junction plane), two main methods (with many variants) are used. The first and simplest puts a narrow conductive stripe on the p-side of the device to limit the injected current to a line, giving a gain-guided laser. There is some spreading of current under the stripe, and the light is restricted only by absorption in the unpumped regions of the junction. The transverse mode of the laser light is therefore not tightly controlled. Many high-power diode lasers, used for instance in side-pumping another solid-state laser (where mode control is less critical), are gain guided.

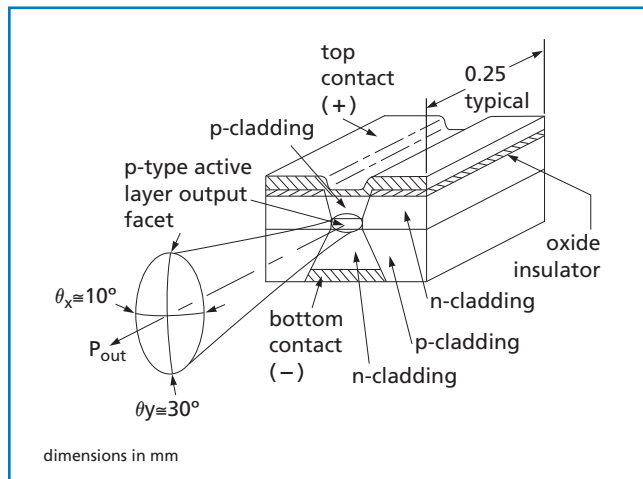

Figure 10.21 Schematic of a double heterostructure index-guided diode laser

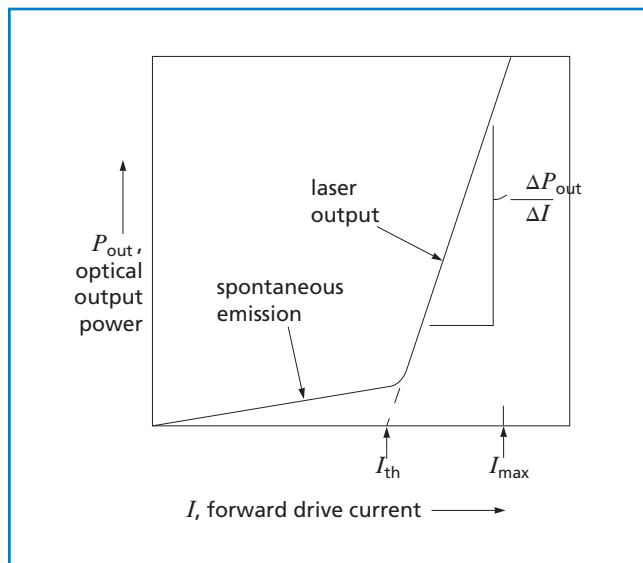

Figure 10.22 Definition of threshold current, I_{th} , and slope efficiency from the curve of light output, P_{out} vs drive current I

More efficient lateral laser mode control is achieved by fabricating, with multiple photolithographic, epitaxial, and etching steps, regions of low index of refraction on either side of the lasing stripe (the two lateral n-cladding regions in the upper half of figure 10.21). This confines the light by waveguiding between planes perpendicular to the junction plane as well giving an index-guided laser. These lasers produce a stable single transverse mode of lowest order, as required in data storage applications to read compact discs, and telecommunications applications where coupling into a fiber optic is important.

Threshold current and slope efficiency definitions

Output power from a diode laser increases linearly with the drive current excess above the threshold current (see figure 10.22). This steeply rising light output curve is extrapolated backward to the zero light output intercept to define the threshold current; the weak incoherent light emission for currents below threshold is due to the spontaneous recombination of carriers such as occurs in LEDs.

When divided by the drive voltage V , the slope of the output vs current curve yields the differential (above threshold) electrical-to-optical power conversion efficiency (also termed the slope or quantum efficiency) which ranges from 50 to 80 percent for various devices.

$$\text{Slope efficiency} = \frac{\Delta P_{\text{out}}}{V \Delta I} . \quad (10.25)$$

Fabrication methods and quantum wells

Three types of epitaxial crystal growth are employed in fabricating the layers of semiconductor alloys for diode laser chips: liquid phase epitaxy (LPE), metal-organic chemical vapor deposition (MOCVD), and molecular beam epitaxy (MBE).

Most early diode lasers were made by the LPE process, and it is still in use for many commercial diode lasers and LEDs. In this process, a heated, saturated solution is placed in contact with the substrate, and it is cooled, leaving an epitaxial film grown on the substrate. High-quality crystal layers are readily produced by this technique, but it is hard to control alloy composition. Furthermore, making thin layers is difficult. Because Quantum well (QW) structures, discussed below, require very thin layers. The LPE process is not appropriate for these devices; they are fabricated using the MOCVD or MBE process.

In the MOCVD process, gases transport the reactants to the heated substrate, where they decompose and the epitaxial layer slowly grows. In the high-vacuum MBE process, the reactants are evaporated onto the substrate, giving a very slow, controlled epitaxial growth. The equipment for MBE is more expensive, and the process is slower making this process most suitable for critical and complex devices of low production volume.

The emergence of the MOCVD and MBE processes made possible improved diode lasers employing quantum well structures as their active regions. A quantum well is a layer of semiconductor of low electron (or hole) potential energy between two other layers of higher potential energy. The well layer is made thin enough, typically less than $0.01 \mu\text{m}$, to be comparable

in size to the Bohr radius of the electron (or hole) in the material. This brings in quantum effects—the confined carrier acts, in the direction perpendicular to the layer plane, as a one-dimensional particle in a potential well. In practical terms, the density of carriers is greatly increased in this QW structure, and the laser threshold current decreases by an order of magnitude. The laser's active region is effectively an engineered, man-made material whose properties can be designed.

There is a disadvantage to QW lasers: the active region is too thin to make a reasonable waveguide. This problem is solved by inserting intermediate layers of graded index between the QW and both cladding layers. This is termed the graded-index separate-confinement heterostructure (GRINSCH) since the carriers are confined to the QW while the laser mode is confined by the surrounding layers. The electrical and optical confinements are separate. For higher output power, several QWs separated by buffer layers can be stacked on top of one another,—a multiple quantum well (MQW) structure. A structure with only one quantum layer is designated a single quantum well (SQL) to distinguish it from a MQW.

The lasing wavelength in QW lasers is determined by both the bulk band gap and the first quantized energy levels; it can be tuned by varying the QW thickness. Further adjustment of the wavelength is possible with strained quantum QWs. If an epitaxial layer is kept below a critical thickness, an alloy with a lattice mismatch to the substrate will distort its lattice (in the direction normal to the substrate) to match the substrate lattice instead of causing misfit dislocations. The strain in the lattice of the resulting QW changes its band gap, an effect taken advantage of to put the lasing wavelength into a desired region.

Wavelength stabilization with distributed, surface-emitting output geometries

The wavelength of a AlGaAs diode laser tunes with substrate temperature at a rate of about $0.07 \text{ nm}/^\circ\text{C}$, a rapid enough rate that many applications require the baseplate of the device to be mounted on a temperature controlled thermoelectric cooler to maintain wavelength stability. Wavelength, threshold current, and efficiency are all sensitive to changes in temperature. If the laser baseplate temperature is allowed to drift, in addition to this long-term shift in wavelength, the output oscillation will jump between drifting longitudinal cavity modes and thus exhibit small, rapid, discontinuous changes in wavelength and/or output power which often are undesirable.

To address this issue, gratings are fabricated into the laser, either at the ends of the gain stripe to create a distributed Bragg reflector (DBR) structure, or along the whole length of the gain region to create a distributed feedback (DFB) structure. The grating has a period on the order of 200 nm and is fabricated using interferometric techniques. (The beam from an argon or HeCd laser is split into two; the beams are then overlapped to create fringes, which in turn are used to expose the photoresist in the photolithography process.) The gratings work by providing a small reflected feedback at each index step. The single frequency whose multiple feedback reflections add up in phase determines the lasing wavelength and stabilizes it against changes in drive current and baseplate temperature.

Because the laser operates in a single frequency, noise is also reduced. DBR and DFB lasers are used extensively as telecommunication light sources.

The DFB laser is an edge emitter. In the second-order gratings fabricated in both DFB and DBR lasers, the first-order diffraction is perpendicular to the surface of the grating. By providing an output window on one of the gratings in a DBR laser, the output can be brought out through the surface of the chip, i.e., a surface-emitting laser.

Recently, another surface-emitting structure, the vertical-cavity surface-emitting laser (VCSEL), has come into use in telecommunication links. In this structure (see figure 10.23) multilayer mirrors are fabricated on the top and bottom of the QW gain region to give feedback. Consequently, the laser output is perpendicular to the active QW plane.

The epitaxial growth process of this structure is more difficult than that for edge emitters. This is because provision must be made to channel current flow around the mirrors to reduce device resistance (for clarity, the bypass channels are omitted in figure 10.23) and because precise control of the mirror layer thicknesses is needed to locate standing wave peaks at the QW active layer(s). Countering these drawbacks, by having no facets to cleave, these lasers have a similar topology to LEDs. They can be tested at the wafer level and packaged using similar low-cost manufacturing methods. In addition, VCSELs have large-area circular beams (defined by the circular limiting aperture of the mirrors) and low threshold currents so they couple well into optical fibers and fit well in low-power (~ 1 mW) communication system applications.

Diode laser beam conditioning

Because the emitting aperture is small on a typical diode laser, beam divergences are large. For example, the emitting area for the index-guided laser shown in figure 10.21 might be as small as $3 \times 1 \mu\text{m}$, resulting in divergences of 10×30 degrees. The optics needed to collimate this beam or to focus it into a fiber must work at a high numerical aperture, resulting in potential lens aberrations, and requiring critical focusing because of short depth of field. Focal lengths must be kept short as well or the optics rapidly become large. The beam itself is elliptical and may be astigmatic. It is often desirable to first circularize the beam spot with an anamorphic prism pair or cylinder lens before coupling the laser output into an optical train. Higher-power lasers with high-order modes cause additional problems when coupling their beams into a fiber or optical system. A wide variety of specialized components are available to address these issues, from molded miniature aspherical lenses to hyperbolic profile fiber cylinder lenses, but all require critical focusing adjustment in their mounting into the laser diode housing. For these reasons many diode lasers are offered with beam-correcting optics built in by the manufacturer who has the appropriate tooling for the task. Typically these lasers are available as collimated units, or as fiber-coupled ("pigtailed") devices.

High-power diode lasers

Single transverse mode diode lasers are limited to 200 mW or less of output power by their small emitting aperture. The facet area is so small (about $3 \times 1 \mu\text{m}$) that this power still represents a high irradiance

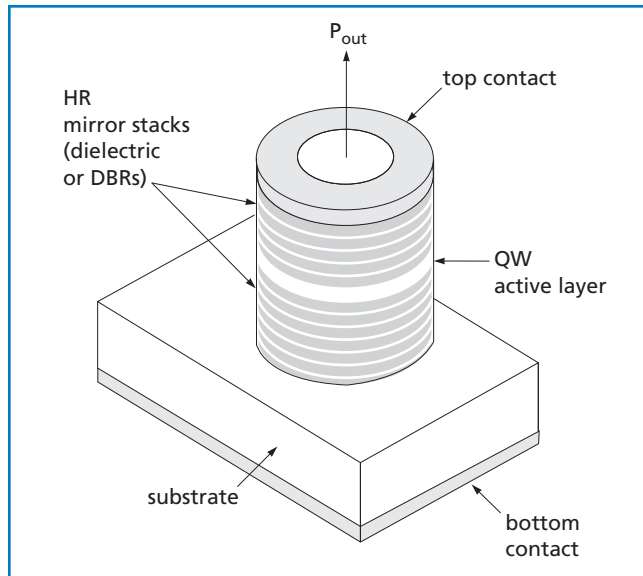

Figure 10.23 Schematic of the VCSEL structure, with light emitted perpendicular to the active layer

($\sim 1 \text{ MW/cm}^2$). The output is limited to this level to stay safely under the irradiance that would cause damage to the facet.

Enlarging the emitting area with an increase of the lateral width of the active stripe is the most common method of increasing the laser output power, but this also relaxes the single transverse mode constraint. Multiple transverse lateral modes, filaments, and lateral mode instabilities arise as the stripe width increases. For example, in a GaAs laser running at 808 nm, the output power rises linearly from 500 mW to 4 W as the lateral width of the emitting aperture increases from 50 to 500 μm . However, the M^2 value of the beam in this plane increases from 22 to 210. The M^2 increase makes it difficult to couple these devices to fibers, but they find considerable application in pumping solid-state laser chips designed to accept a high-numerical-aperture focus.

The pump diode lasers for even higher-power DPSS lasers are made as linear arrays of 20 or more stripe emitters integrated side by side on a 1-cm-long semiconductor bar. The bar is mounted in a water-cooled housing to handle the heat load from the high drive current. These diode laser arrays provide from 20 to 40 W of continuous output power at wavelengths matching the absorption bands of different laser crystals (e.g., 808 nm for pumping Nd:YAG lasers). The individual stripe emissions are not coherently related, but bars can be used to side pump a laser rod, just as the arc lamps they replace formerly did. Another common delivery geometry is a bundle of multimode fibers, fanned into a line of fibers on one end with each fiber butted against an individual stripe on the bar, with the other end of the bundle gathered into a circular grouping. This converts the bar output into a round spot focusable onto the end of the crystal to be pumped.

Finally, for even more output, a few to a dozen bars are mounted like a deck of cards one on top of another in a water-cooled package, connected in series electrically, and sold as a stacked array. These can deliver in excess of 500 W output power from one device.

Packaging, power supplies, and reliability

For low-power lasers, the industry uses standard semiconductor device package designs, hermetically sealed with an output window. Lasers with higher power dissipation come with a copper baseplate for attachment to a finned heat sink or thermoelectric cooler (TEC). Many are offered coupled into a fiber at the manufacturing plant in a pigtailed package (with an output fiber attached) because of the criticality in mounting the coupling optics as mentioned above.

Careful heat sinking is very important because all the major device parameters—wavelength, threshold current, slope efficiency, and lifetime—depend on device temperature (the cooler, the better). Temperature-servoed TECs are preferred for stable operation with the temperature sensor for feedback mounted close to the diode laser.

Diode lasers are susceptible to permanent damage from static electricity discharges or indeed any voltage transient. Their low operating voltage (~2 V) and ability to respond at high speed means that a static discharge transient can be a drive current spike above the maximum safe level and result in catastrophic facet damage. All the usual antistatic electricity precautions should be taken in working with diode lasers: cotton gloves, conductive gowns, grounded wrist straps, work tables, soldering irons, and so on. Correspondingly, the drive current power supply should be filtered against surges and include “slow starting” circuitry to avoid transients.

Diode lasers degrade with high power and long operating hours as crystal defects migrate and grow, causing dark lines or spots in the output mode pattern and increases in threshold current or decreases in slope efficiency. The best way to prolong life is to keep the laser baseplate running cool. Remember that accelerated life tests are run by operating at high baseplate temperature. Expectations for the median life of a device are set from measurements of large populations—individual devices can still suddenly fail. Nevertheless, the industry expectations today for standard diode lasers run within their ratings is $\sim 10^5$ hours of operation for low-power diode lasers and perhaps an order of magnitude less for the high-power versions.

Summary of applications

The applications mentioned in the discussion above, and a few others, are summarized in the following table and ordered by wavelength. The newer GaN lasers provide low power (10–100 mW) blue and UV wavelengths finding applications as excitation sources for biomedical fluorescence studies (DNA sequencing, confocal microscopy). The dominant application for diode lasers is as readouts for optical data storage, followed by growing numbers in use in telecommunications. For high-power (>1 W) diode lasers, the main application is as optical pumps for other solid state lasers.

OPTICALLY PUMPED LASERS

Optically pumped lasers use photons of light to directly pump the lasing medium to the upper energy levels. The very first laser, based on a synthetic ruby crystal, was optically pumped. Optically pumped lasers can be separated into two broad categories: lamp-pumped and laser pumped. In a lamp-pumped laser, the lasing medium, usually a solid-state crystal, is placed near a high-intensity lamp and the two are surrounded by an elliptical reflector that focuses the light from the lamp into the crystal, as shown in figure 10.24. In laser-pumped systems, the light from another laser is focused into a crystal (or a stream of dye), as shown in figure 10.25.

In general, ignoring the efficiency of the pump laser itself, laser pumping is a much more efficient mechanism than lamp pumping because the wavelength of the pump laser can be closely matched to specific absorption bands of the lasing medium, whereas most of the light from a broad-spectrum lamp is not usefully absorbed in the gain medium and merely results in heat that must be removed from the system. Furthermore, the size of the laser pump beam can be tightly controlled, serving as a gain aperture for improving the output mode characteristics of the pumped laser medium. On the other hand, laser pumping is often not suitable for high-energy applications where large laser crystals are required.

Diode-pumped solid-state (DPSS) lasers, a class of laser-pumped lasers, will be discussed in detail below.

DIODE-PUMPED SOLID STATE LASERS

The DPSS laser revolution

The optical difficulties encountered with diode lasers—difficulty in coupling to the high divergence light, poor mode quality in the slow axis of wide-stripe lasers, low output power from single-transverse-mode lasers—led to a new philosophy (figure 10.26) about how best to use these efficient, long-lived, compact light sources. This concept, championed in the 1980s by a group at Stanford University headed by Prof. Bob Byer, has been termed the diode-pumped solid state (DPSS) laser revolution.

The logic is simple. The primary light source (the diode laser) pumps another laser (an infrared crystal laser) to convert to a good mode, the beam of which is wavelength converted (by nonlinear optics techniques) to a visible output. The diode laser source replaces the discharge lamp for optically pumping the gain crystal in a traditional, high-efficiency, infrared laser. The infrared beam is generated in that independent resonator with a good mode, and consequently it can be efficiently converted with an intracavity nonlinear crystal to a visible beam with a good mode. Though power is lost at each step, the result is still a single-mode visible beam generated with a total electrical-to-optical conversion efficiency of several percent. These DPSS lasers are replacing the older visible gas lasers whose conversion efficiencies rarely reach 0.1 percent.

End- and side-pumping geometries

The first DPSS lasers were made by focusing the diode light from a single laser diode emitter through the high-reflector coating (at 1.06 μm) on the

Diode Laser Applications

Wavelength λ (nm)	Lattice Material*	Application
375	GaN	Biomedical fluorescence
405	GaN	Biomedical fluorescence, DVD mastering, direct-to-plate
440	GaN	Biomedical fluorescence, HeCd laser replacement
473	GaN	Biomedical fluorescence
488	GaN	Biomedical fluorescence
635–640	GaAs	Pointers, alignment, HeNe laser replacement
650–680	GaAs	Biomedical fluorescence, barcode scanners, pointers, alignment, surgical
780	GaAs	Audio CD readouts
785	GaAs	Raman spectroscopy
808	GaAs	Optical pumps for Nd:YAG lasers, thermal printing
940	InP	Optical pumps for Yb:YAG lasers
980	InP	Optical pumps for Er fiber telecom amplifiers
1310	InP	Input source for telecom short-wavelength channels, OCT
1455	InP	Optical pump for Raman gain in standard telecom fiber
1550	InP	Input source for telecom long-wavelength channels

*Ga, Al, In, P dopants are added to form the required layered structures

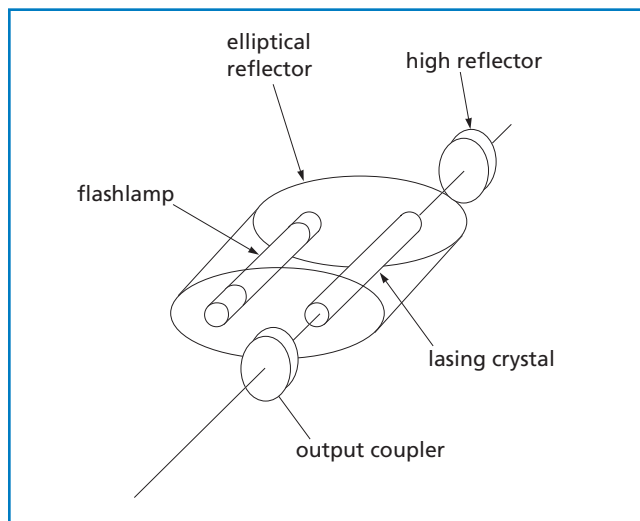

Figure 10.24 Schematic of a lamp-pumped laser

end of the Nd:YAG rod. This "end-pumping" geometry provide good overlap between the pumped volume and the lasing volume, but it limited the pump power to that available from single-mode diode emitters.

In order to increase laser output and reduce cost (diode lasers suitable for end pumping are twice as expensive as diode laser arrays), diode arrays were mounted along the length of the laser rod. However, because of poor overlap of the pump beam with the 1.06 μm beam, the efficiency of this "side-pumping" technique was only half that of end-pumping geometries. No pump diode cost savings resulted.

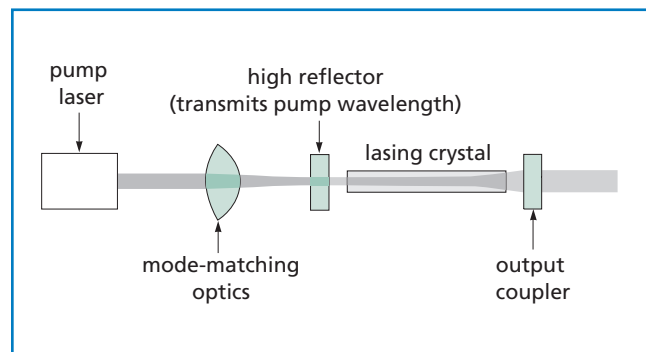

Figure 10.25 Schematic of a laser-pumped laser

Then in the late 1980s two advances were made. First, a variety of new laser rod materials, better tailored to take advantage of diode laser pumps, were introduced. Nd:YVO₄ crystals have five times the gain cross section of Nd:YAG, and the Nd can be doped into this crystal at much higher concentrations. This decreases the absorption depths in the crystal from cm to mm, easing the collimation or focusing quality required of the pump beam. This crystal had been known, but could be grown only to small dimensions, which is acceptable for diode-pumped crystals. Another crystal introduced was Yb:YAG, pumped at 980 nm and lasing at 1.03 μm leaving very little residual heat in the crystal per optical pumping cycle and allowing small chips of this material to be pumped at high levels.

Second, means were devised to make micro-cylindrical lenses (focal lengths less than a mm) with the correct surfaces (one type is a hyperbolic profile) for collimating or reducing the fast-axis divergence of the diode laser output. With good tooling and beam characterization these are correctly

positioned in the diode beam and bonded in place to the diode housing. This allows more conventional lenses, of smaller numerical aperture, to be used in subsequent pump light manipulations.

End-pumping with bars

With these two new degrees of freedom, laser designers realized they could create optical trains that would give them end-pumping system efficiencies (achieve good overlap between pump and lasing modes) with diode arrays as pump sources to obtain a lower diode cost per watt in their systems. This produced an explosion of unique DPSS laser designs generically described as "end-pumping with bars."

Figure 10.27 shows the example previously mentioned, delivering the array light through a fiber bundle, with the fibers at one end spread out to butt align with the linear stripes of an array, and the other end of the bundle gathered to an approximately circular spot.

Although the circular spot is large, its focal image, formed with high numerical aperture (NA) optics, is small enough to satisfactorily overlap the IR cavity laser mode. The small depth of focus, from the high NA optics, is inconsequential here because of the short absorption depth in the Nd:YVO₄ laser crystal. The laser head can be disconnected from the diode modules at the fiber coupler without loss of alignment.

In another example, an even higher-NA optic (comprising a cylinder lens and a molded aspheric lens) was used to directly focus the 1-cm width of a micro-lensed array bar onto the end of a Nd:YVO₄ gain crystal. This produced an oblong pump spot, but good overlap with the IR cavity mode was achieved by altering the infrared cavity (inserting two intracavity beam expansion prisms in that arm) to produce a 5:1 elliptical cavity mode in the gain crystal. Another design used a nonimaging pyramidal "lens duct" to bring in the pump light from a diode laser stack to the end of a gain crystal. Yet another brought light from several arrays into a lasing rod centered in a diffuse-reflecting cavity by means of several planar (glass-slide) waveguides, each piercing a different sector of the reflector sidewall. These are but a few of the design approaches that have been successfully taken.

488 nm Solid-State Lasers

A variety of solid-state approaches are used to achieve 488 nm output, a popular wavelength used for excitation of fluorophores in biotech applications. One approach, optically pumped semiconductor lasers (OPSL), utilizes a diode to pump a solid state gain chip atop a Bragg reflector which then passes through an external non linear crystal to double the 976 nm fundamental radiation down to 488 nm. The OPSL approach typically requires a large number of components and more complex fabrication, coating and assembly compared to other approaches that follow. True DPSS approaches utilize a pump diode, two gain mediums and a frequency mixing of 914 and 1064 nm radiation along with a single frequency generator to produce 491 nm, a wavelength close, but not quite optimum for the narrow bandwidth filters and fluorophores used in these applications. Directly doubled diodes (DDD) offer the best of both worlds by generating both the optimum 488 nm wavelength and a minimal number of components to achieve it (see figure 10.28). DDD's use a pump diode at 976 nm and unlike other doubled diode laser approaches which use external cavity components, an integrated nonlinear crystal/cavity. This approach results in a laser that is highly efficient, robust and volume manufacturable.

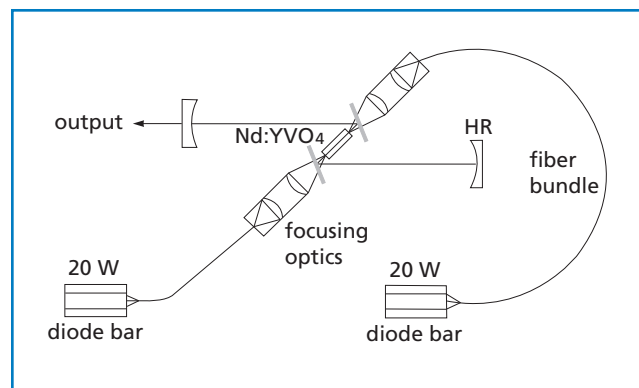

Figure 10.27 Schematic of an "end-pumping with bars" geometry using fiber bundle delivery, one of many variants on the DPSS laser theme

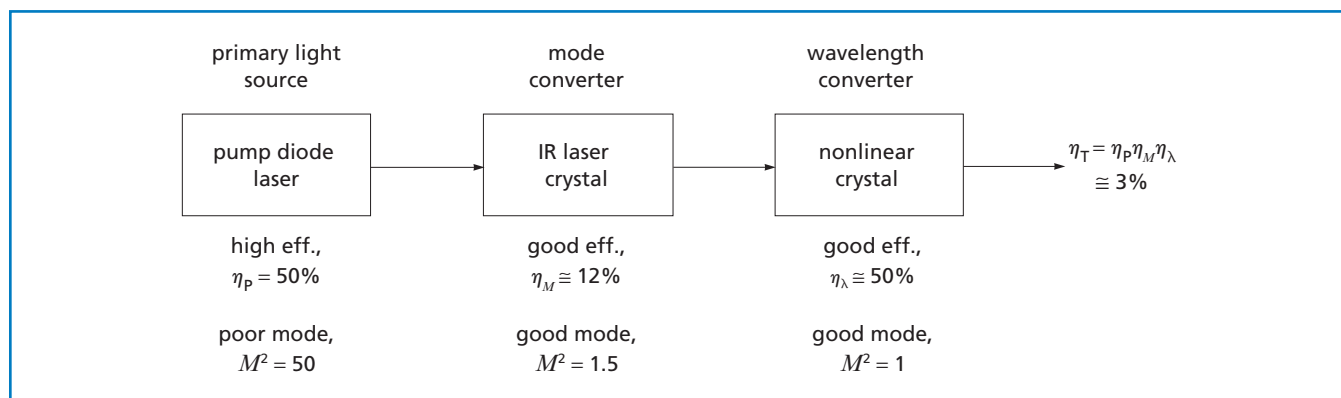

Figure 10.26 The logic for DPSS lasers

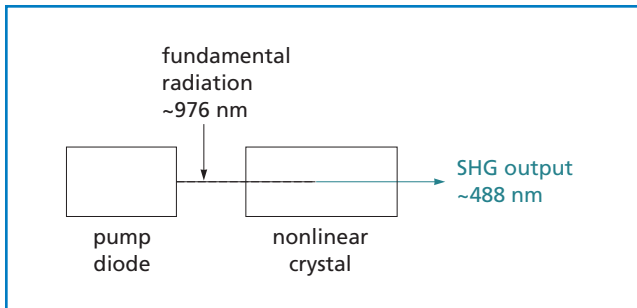

Figure 10.28 **Directly doubled diodes**

Microchip lasers

Another procedure that can be used to make available potentially inexpensive, mass produced, low power, visible output DPSS lasers is mimicking semiconductor chip processing methods. In the late 1980s, MIT Lincoln Labs took this approach and created the “microchip” laser. A thin Nd:YVO₄ plate is polished flat and then diced into ~2-mm-square chips. Each of these chips is then optically contacted to similar, flat, diced KTP doubling crystal plates to make a cube. Prior to dicing, the surfaces that will become the outer cube surfaces are coated for high reflectivity at 1.06 μm. When single-mode diode laser pump light is focused through one mirrored end of the cube, the heat produced makes a thermally-induced waveguide that creates a stable cavity for IR lasing. Since the KTP crystal is within this cavity, the IR lasing is converted to a 532-nm (green) output beam with 10’s of milliwatts of output. The diode temperature must be controlled to maintain a stable pump wavelength and thermal waveguide. In addition, the cube temperature should be stabilized. Because of the short cavity, the IR laser operates at a single longitudinal mode, and the cavity length must be thermally tuned to keep the mode at the peak of the gain curve. Laser operation in a single frequency suppresses “green noise,” discussed next.

The “green noise” problem

As the early DPSS laser designs giving visible-output beams were being introduced, it became apparent that there was a problem unique to this architecture. The visible output power, 532 nm in the green spectrum, could break into high-frequency chaotic oscillations of nearly 100-percent peak-to-peak amplitude. This was named the “green problem” by Tom Baer (then at Spectra-Physics), who in 1986 showed the effect to be due to the dominance of sum-frequency-mixing (SFM) terms coupling different longitudinal modes over second-harmonic-generation (SHG) terms, in the nonlinear conversion step from IR to visible output. Several conditions (all met by the new laser designs) lead to this effect: (1) the IR laser cavity is short (~10 cm or less) with only a few longitudinal modes oscillating, (2) nonlinear conversion efficiencies are high (20% or more), and (3) nonlinear phase-matching bandwidths span several longitudinal mode spacings (true of the commonly used KTP doubling crystal). Then the sum frequency mixing output losses couple the longitudinal modes in relaxation oscillations where the turn on of one mode turns off another.

Two early solutions to this problem emerged. The first is to make the IR cavity long enough to give hundreds of oscillating modes, so that the noise terms average to insignificance as in a long gas laser. The second is to make the IR oscillation run on a single longitudinal mode so that there are no SFM terms. This can be done by using intracavity frequency control elements such as an etalon, or by using a ring cavity (with a Faraday-effect biasing element to maintain the direction of light travel around the ring). Ring cavities eliminate the standing-wave interference effect of linear cavities, termed “spatial hole burning,” and the laser runs single frequency when this is done. As more experience was gained with DPSS laser design, other clever solutions to the “green problem” were found, tailored to each particular device and often held as trade secrets. It can be surmised that these involve precise control of wavelength, spatial hole burning, beam polarization, and cavity-element optical path differences to reduce the strength of longitudinal mode SFM terms.

Uniqueness of DPSS laser designs and laser reliability

Unlike the gas lasers they replace, no universal approach is applied in the details of different DPSS laser designs and laser models. There is a large variety of solutions to the major problems, many solutions are unique, and many are held as proprietary. Major design differences are found in:

- the means for optically coupling the pumping light into the gain medium,
- the management of the thermal lens produced by absorption of the pump light in the cavity,
- the control of green noise,
- the strain-free mounting, heat sinking, and placement of the small lasing and nonlinear crystals in the laser cavity, and
- the hermetic sealing of the laser cavity to protect the often delicate crystals and critical alignments of components

Note that because the intracavity space must be hermetically sealed there usually is no field repair, maintenance, or adjustment of a DPSS laser head. If it fails, it is returned to the manufacturer.

It is evident that DPSS lasers are a lot less generic than the gas lasers they replace. For a problem with a particular laser model, there may be no standard solution available in the technical literature. With so many variables, there often are surprises when new designs are first manufactured and introduced. Under these circumstances, the user is advised to pick a supplier with a record of years of consistent manufacture, who has over time dealt with his own unique set of component and assembly problems. If this advice is followed, then the expectation with current products is that a new DPSS laser will operate reliably for 10,000 hours or more.

561 nm DPSS Laser

The newest addition to the CVI Melles Griot laser product line is a DPSS laser with yellow output at 561 nm, an ideal excitation wavelength for biomedical fluorescence.

This 16.5-cm-long laser head delivers up to 75 mW of output power, and consumes less than 10 W of wall plug power at 25 mW and less than 18 W at 75 mW. The laser is pumped by a single stripe diode laser. Frequency-selective elements in the cavity limit IR oscillation to the 1.123 μm Nd line (one of the weaker lines in the 1.064 μm manifold) and constrain this oscillation to a single longitudinal mode. The output is low noise (0.5 percent rms) with excellent mode quality ($M^2 < 1.2$). Polarization is vertical with respect to the mounting surface with an extinction ratio of $>100:1$.

An example of a DPSS laser product line—the CVI Melles Griot visible output lasers

Figure 10.29 depicts the mix of laser crystals, laser operating wavelengths, and doubling crystals generating the four visible output wavelengths of the present CVI Melles Griot product line of continuous wave DPSS lasers.

Other notable DPSS lasers

A brief discussion of three other significant DPSS laser developments conclude this section.

The *Er-doped fiber amplifier (EDFA)* is not a laser, but it is an optically pumped amplifier for the 1550-nm long-wavelength long-haul fiberoptic channels that make the worldwide web possible. Pumping an Er-doped silica fiber with 980-nm diode laser light inverts the populations of energy levels in the Er ions to provide gain for optical telecommunication signals run through the same fiber. This optical amplifier is much simpler than the discrete electronic repeaters it replaced. A Lucent Technologies executive expressed the importance of this when he said: "What broke [wavelength division multiplexing telecommunications] free was the invention of the [EDFA] optical amplifier."

The *Q-switched industrial DPSS laser* is a 1-W-average-power, ultraviolet (355 nm), high-repetition-rate (30 kHz) system. Output is obtained by doubling the 1.064- μm Q-switched fundamental to green at 532 nm, and then mixing the green beam with the residual transmitted infrared to 355 nm. This process is straightforward in a high-peak-power pulsed beam—just a matter of inserting the appropriate doubling and tripling crystals. What is remarkable is that DPSS laser designs have matured sufficiently to make this possible in a hands-off, long lived, system rugged enough to survive and be useful in an industrial environment.

The *double-clad fiber laser* is shown in figure 10.30. Fiber lasers work by optically pumping (with a diode laser) a doped fiber and adding mirrors for feedback at either end of the fiber. In the dual-clad fiber, the Yb-doped single-mode fiber core is surrounded by a large diameter cladding (with a corrugated star-shaped cross section in the figure) that is itself clad by a low-index polymer coating. Diode laser light at 940 nm is readily launched into and guided in the large diameter outer cladding, and the corrugated cross-section of this fiber suppresses the helical ray modes of propagation that would have poor overlap with the inner core. Over the length of the fiber, the pump light is absorbed by the single-mode core, and high-power lasing near 1.03 μm in a low-order mode is produced. The quantum efficiency of the Yb lasing cycle (ratio of pump wavelength to lasing wavelength) is 91 percent, which leaves little heat deposited in the fiber. Over 1 kW of output at 80-percent slope efficiency has been produced in such a fiber laser. These will become important laser sources for industrial applications.

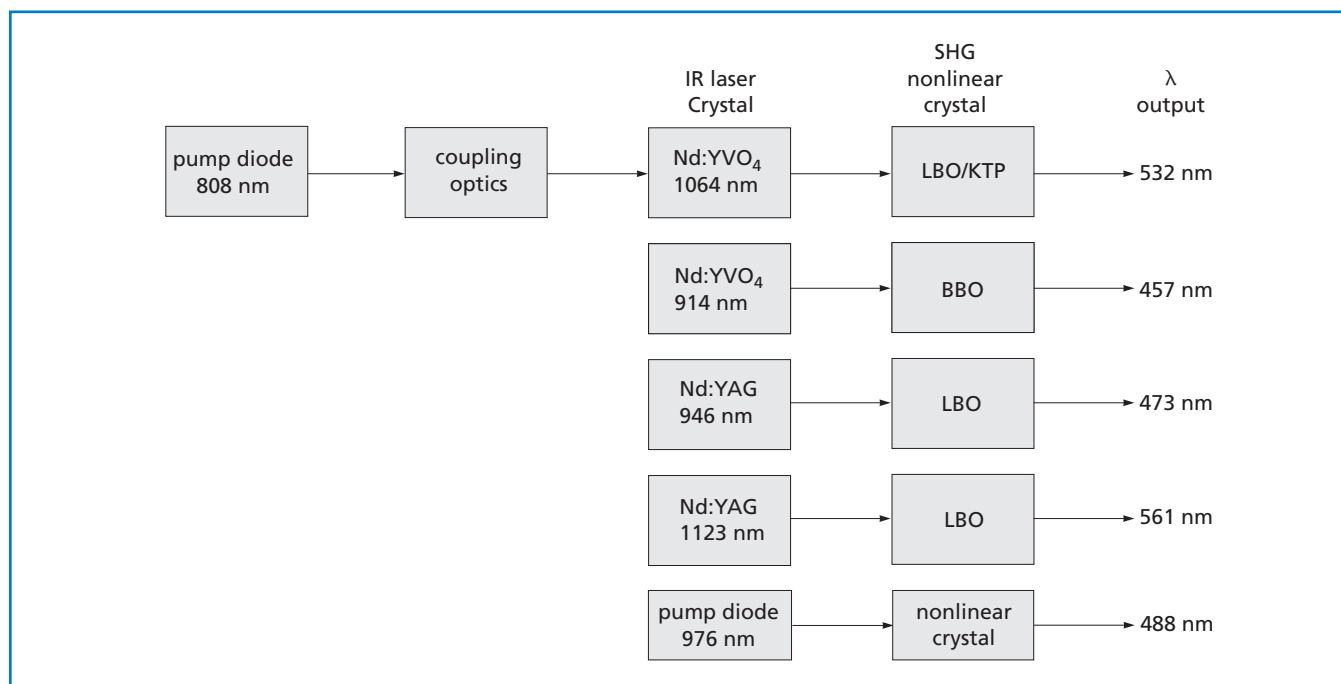

Figure 10.29 CVI Melles Griot solid-state laser optical trains for producing five different visible output wavelengths

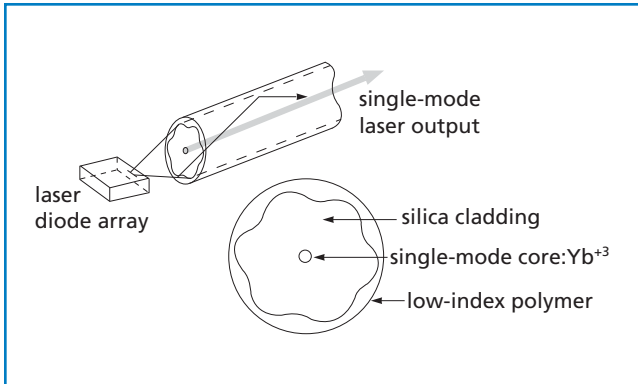
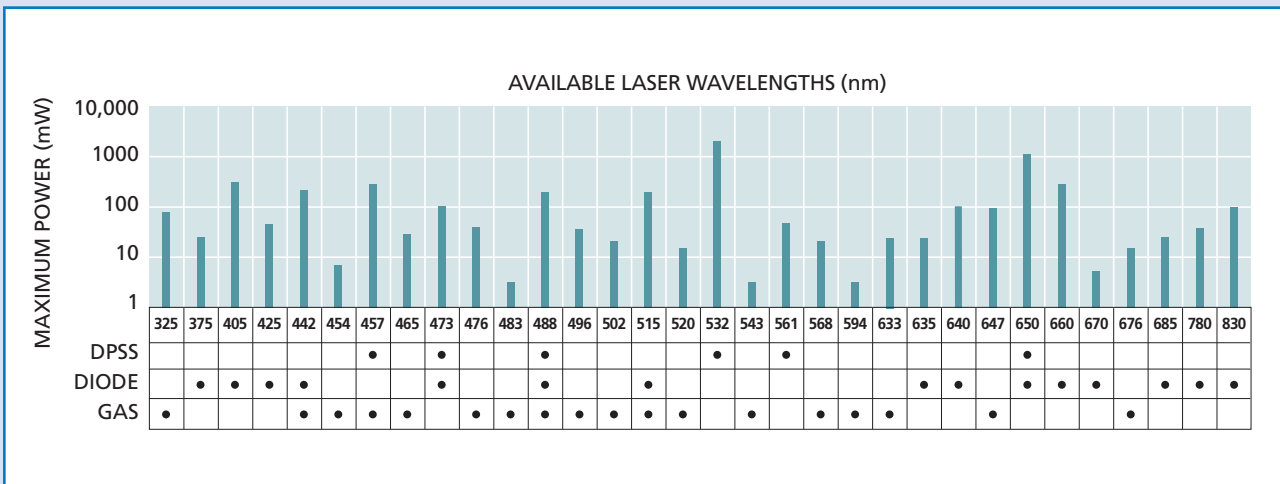

Figure 10.30 Schematic diagram of the structure of a double-clad fiber, and the method of pumping the inner core by direct illumination into the large diameter of the outer cladding



561-nm yellow diode pumped solid-state laser

Available Wavelengths



Technology and spectral offering