

Lens Selection

The most important relationships that we will use in the process of lens selection for Gaussian-beam optical systems are focused spot radius and beam propagation.

Focused Spot Radius

$$w_F = \frac{\lambda f M^2}{\pi w_L} \quad (2.33)$$

where w_F is the spot radius at the focal point, and w_L is the radius of the collimated beam at the lens. M^2 is the quality factor (1.0 for a theoretical Gaussian beam).

Beam Propagation

$$w_R(z) = w_{0R} \left[1 + \left(\frac{z \lambda M^2}{\pi w_{0R}^2} \right)^2 \right]^{1/2}$$

and

$$R_R(z) = z \left[1 + \left(\frac{\pi w_{0R}^2}{z \lambda M^2} \right)^2 \right]$$

and

$$w_0(\text{optimum}) = \left(\frac{\lambda z M^2}{\pi} \right)^{1/2}$$

where w_{0R} is the radius of a real (non-Gaussian) beam at the waist, and $w_R(z)$ is the radius of the beam at a distance z from the waist. For $M^2 = 1$, the formulas reduce to that for a Gaussian beam. $w_0(\text{optimum})$ is the beam waist radius that minimizes the beam radius at distance z , and is obtained by differentiating the previous equation with respect to distance and setting the result equal to zero.

Finally,

$$z_R = \frac{\pi w_0^2}{\lambda}$$

where z_R is the Raleigh range.

We can also utilize the equation for the approximate on-axis spot size caused by spherical aberration for a plano-convex lens at the infinite conjugate:

$$\text{spot diameter (3}^{\text{rd}}\text{-order spherical aberration)} = \frac{0.067 f}{(f/\#)^3}$$

This formula is for uniform illumination, not a Gaussian intensity profile. However, since it yields a larger value for spot size than actually occurs, its use will provide us with conservative lens choices. Keep in mind that this formula is for spot diameter whereas the Gaussian beam formulas are all stated in terms of spot radius.

EXAMPLE: OBTAIN AN 8-MM SPOT AT 80 M

Using the CVI Melles Griot HeNe laser 25 LHR 151, produce a spot 8 mm in diameter at a distance of 80 m, as shown in figure 2.16

The CVI Melles Griot 25 LHR 151 helium neon laser has an output beam radius of 0.4 mm. Assuming a collimated beam, we use the propagation formula

$$w_0(\text{optimum}) = \left(\frac{\lambda z M^2}{\pi} \right)^{1/2}$$

to determine the spot size at 80 m:

$$w(80 \text{ m}) = 0.4 \left[1 + \left(\frac{0.6328 \times 10^{-3} \times 80,000}{\pi (0.4^2)} \right)^2 \right]^{1/2}$$

$$= 40.3\text{-mm beam radius}$$

or 80.6-mm beam diameter. This is just about exactly a factor of 10 larger than we wanted. We can use the formula for $w_0(\text{optimum})$ to determine the smallest collimated beam diameter we could achieve at a distance of 80 m:

$$w_0(\text{optimum}) = \left(\frac{0.6328 \times 10^{-3} \times 80,000}{\pi} \right)^{1/2} = 4.0 \text{ mm.}$$

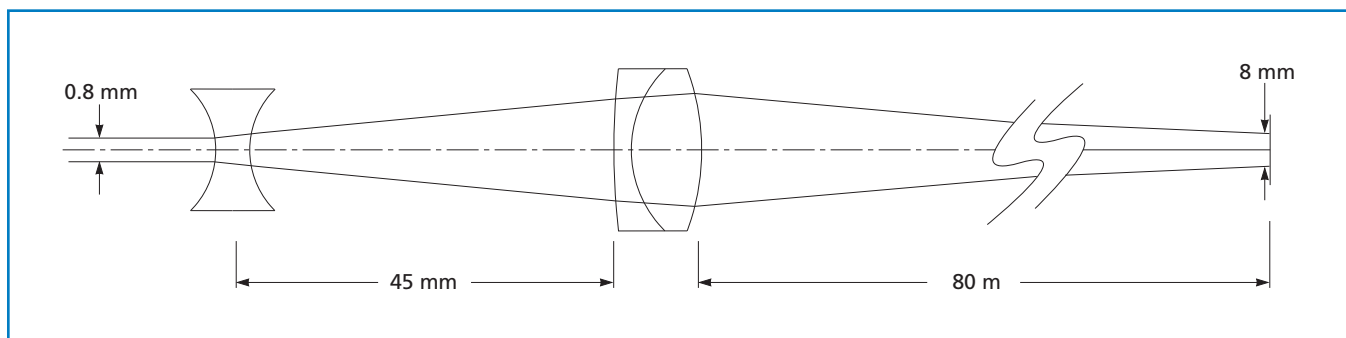

Figure 2.16 Lens spacing adjusted empirically to achieve an 8-mm spot size at 80 m

This tells us that if we expand the beam by a factor of 10 (4.0 mm/0.4 mm), we can produce a collimated beam 8 mm in diameter, which, if focused at the midpoint (40 m), will again be 8 mm in diameter at a distance of 80 m. This $10\times$ expansion could be accomplished most easily with one of the CVI Melles Griot beam expanders, such as the 09 LBX 003 or 09 LBM 013. However, if there is a space constraint and a need to perform this task with a system that is no longer than 50 mm, this can be accomplished by using catalog components.

Figure 2.17 illustrates the two main types of beam expanders.

The Keplerian type consists of two positive lenses, which are positioned with their focal points nominally coincident. The Galilean type consists of a negative diverging lens, followed by a positive collimating lens, again positioned with their focal points nominally coincident. In both cases, the overall length of the optical system is given by

$$\text{overall length} = f_1 + f_2$$

and the magnification is given by

$$\text{magnification} = \frac{f_2}{f_1}$$

where a negative sign, in the Galilean system, indicates an inverted image (which is unimportant for laser beams). The Keplerian system, with its internal point of focus, allows one to utilize a spatial filter, whereas the Galilean system has the advantage of shorter length for a given magnification.

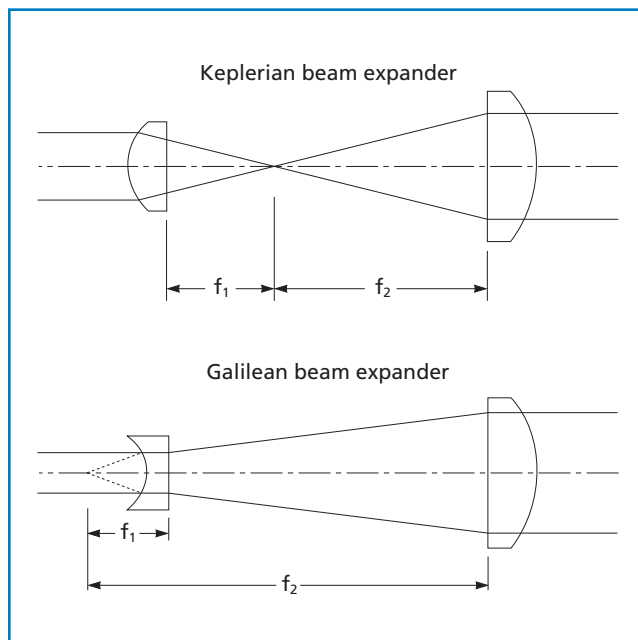

Figure 2.17 Two main types of beam expanders

In order to determine necessary focal lengths for an expander, we need to solve these two equations for the two unknowns.

In this case, using a negative value for the magnification will provide us with a Galilean expander. This yields values of $f_2 = 55.5$ mm] and $f_1 = 45.5$ mm.

$$f_1 + f_2 = 50 \text{ mm}$$

and

$$\frac{f_2}{f_1} = -10.$$

Ideally, a plano-concave diverging lens is used for minimum spherical aberration, but the shortest catalog focal length available is -10 mm. There is, however, a biconcave lens with a focal length of 5 mm (LDK-5.0-5.5-C). Even though this is not the optimum shape lens for this application, the extremely short focal length is likely to have negligible aberrations at this f-number. Ray tracing would confirm this.

Now that we have selected a diverging lens with a focal length of 45 mm, we need to choose a collimating lens with a focal length of 50 mm. To determine whether a plano-convex lens is acceptable, check the spherical aberration formula.

The spot diameter resulting from spherical aberration is

$$\frac{0.067 \times 50}{6.25^3} = 14 \text{ } \mu\text{m}.$$

The spot diameter resulting from diffraction ($2w_0$) is

$$\frac{2 (0.6328 \times 10^{-3}) 50}{\pi 4.0} = 5 \text{ } \mu\text{m}.$$

Clearly, a plano-convex lens will not be adequate. The next choice would be an achromat, such as the LAO-50.0-18.0. The data in the spot size charts indicate that this lens is probably diffraction limited at this f-number. Our final system would therefore consist of the LDK-5.0-5.5-C spaced about 45 mm from the LAO-50.0-18.0, which would have its flint element facing toward the laser.

References

- A. Siegman. *Lasers* (Sausalito, CA: University Science Books, 1986).
- S. A. Self. "Focusing of Spherical Gaussian Beams." *Appl. Opt.* 22, no. 5 (March 1983): 658.
- H. Sun. "Thin Lens Equation for a Real Laser Beam with Weak Lens Aperture Truncation." *Opt. Eng.* 37, no. 11 (November 1998).
- R. J. Freiberg, A. S. Halsted. "Properties of Low Order Transverse Modes in Argon Ion Lasers." *Appl. Opt.* 8, no. 2 (February 1969): 355-362.
- W. W. Rigrod. "Isolation of Axi-Symmetric Optical-Resonator Modes." *Appl. Phys. Lett.* 2, no. 3 (February 1963): 51-53.
- M. Born, E. Wolf. *Principles of Optics Seventh Edition* (Cambridge, UK: Cambridge University Press, 1999).