

Blue Solid-State Laser System 457 nm, 100 to 300 mW

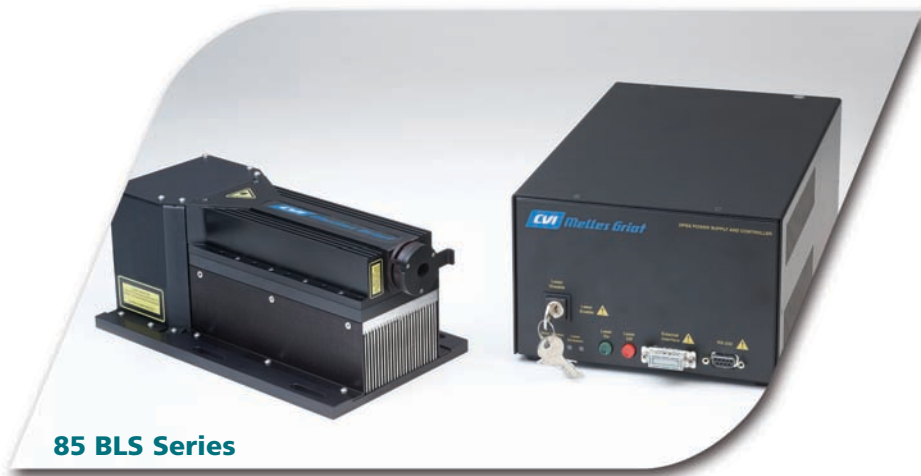

CVI Melles Griot single frequency diode-pumped solid-state blue lasers provide high power output at 457 nm in a compact, air-cooled package. They are ideal for use in semiconductor, biomedical, spectroscopic, interferometric, holographic instrumentation; laser display devices, photo-plotters, PC-board, wafer, and surface inspection equipment, and particle characterization instrumentation. Their single longitudinal mode and long coherence length make them an indispensable tool for holographic applications.

Key Features

- Up to 300 mW at 457 nm
- Single transverse and longitudinal mode
- Coherence length up to 5 m
- Low power consumption
- Universal input voltage power supply
- RS-232 interface
- Automatic power control
- CDRH and CE compliant

Specifications

Beam Characteristics

Output Wavelength	457.5 ± 0.5 nm
M^2	≤ 1.2
Transverse Mode	TEM ₀₀
Longitudinal Mode	Single
Coherence Length	Up to 5 m (ACC mode)
Polarization	Linear (horizontal ± 5°) >100:1
Exit Angle	4° ± 1° (horizontal) 0° ± 1° (vertical)

Stability Characteristics

Long-Term Power Drift	± 2.5% in APC Mode (8 hrs) (ambient ± 2°C) ± 7% in ACC mode (20 min) (ambient ± 2°C after 15 min warmup)
Pointing Stability	<25 μrad (ambient ± 1°C) <7 μrad (ambient ± 1°C with optional 4x beam collimator)

Amplitude Noise <i>rms</i>	<2% (20 Hz to 2 MHz)
-------------------------------	----------------------

Operating Characteristics

Operating Mode	Automatic Current Control (ACC) Automatic Power Control (APC)
Warm-up Time	<15 minutes
Cooling	Forced air with heat sink

Environmental Requirements

Temperature (ambient)	10°C to +35°C
<i>Operating</i>	–10°C to +60°C
<i>Nonoperating</i>	
Operating Humidity	0 to 95%, noncondensing

Electrical Characteristics

Input Voltage	100–240 Vac ± 10%
Input Frequency	50–60 Hz, single phase
Input Power	150 W (typical)
Computer Interface	RS-232

Options

4x beam expander	58-ASB-001
Fan switch	upon special request

Weight

Laser Head	3.9 kg (8.6 lb)
Power Supply	3.7 kg (8.1 lb)

Safety and Regulatory Compliance

CDRH Class	IIIb
IEC Class	3B
CE	Compliant



This CVI Melles Griot laser system meets the following standards:
IEC 60825-1:1997 (EU Laser Safety)
EN 61326:1997/A3:2003 Class A (EU Emissions and Immunity)
21 CFR 1040.10 (US Laser safety)
FCC Part 18 (US Emissions and Immunity)

85 BLS Laser Systems

cw Output Power (mW)	Beam Dimension (1/e ²) (mm)		Beam Shape	Beam Divergence (1/e ²) (mrad)		PART NUMBER
	vertical	x horizontal		vertical	x horizontal	
100	0.125	- 0.155	Round	<5.0		85 BLS 301
200	(0.105 - 0.165) ×	(0.200 - 0.350)	Elliptical (horizontal)	<5.5 × 3.0		85 BLS 305
300	(0.105 - 0.165) ×	(0.200 - 0.350)	Elliptical (horizontal)	<5.5 × 3.0		85 BLS 601

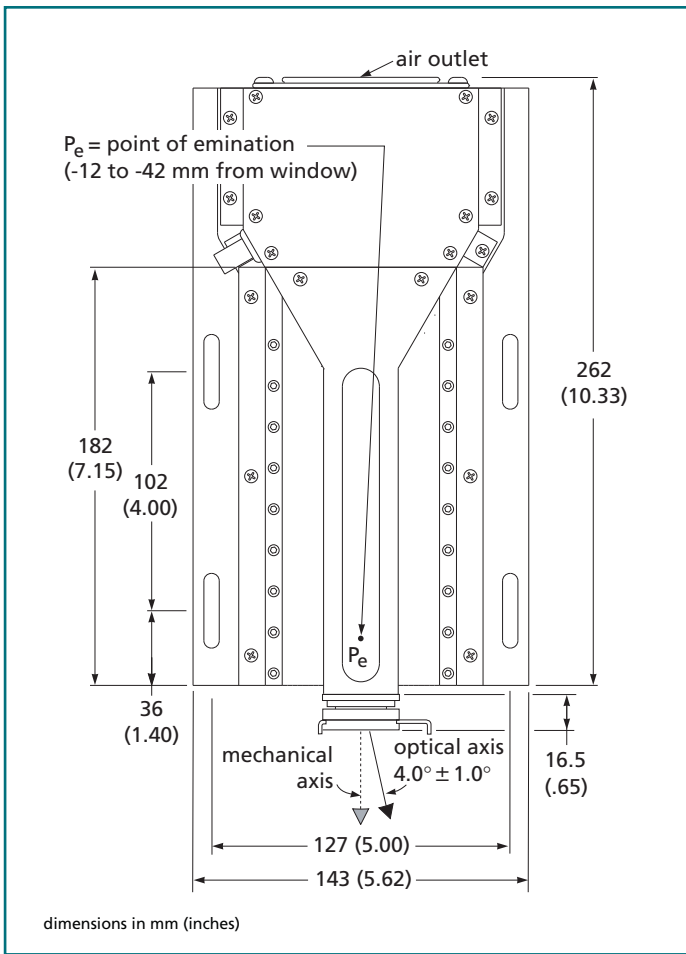

85 BLS-series laser, top view

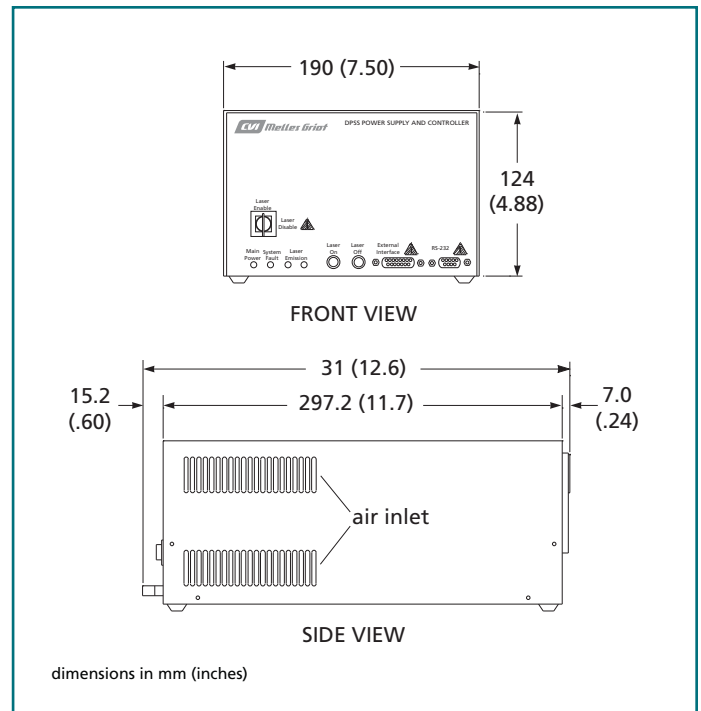

85 BLS-series laser power supply

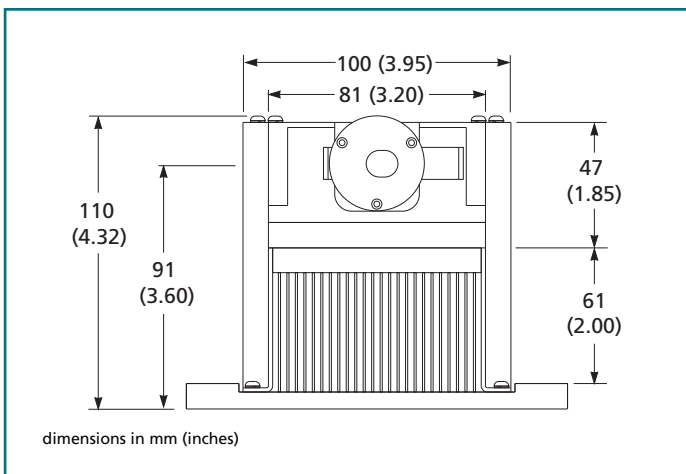

85 BLS-series laser, front view

CVI Melles Griot offers the most complete portfolio of laser technologies in the industry. Wavelengths range from the ultraviolet through the near infrared, with delivered power up to 3 Watts. We also offer design and manufacturing of Laser Electro-Optical Assemblies incorporating multiple laser sources, optics, mechanics and electronics. Reliable assemblies require manufacturing to sub-micron and micro radian tolerances — one of our key competencies. These turnkey “light engines” can dramatically shorten your supply chain, reduce your field service costs, and minimize production complexities. They also come complete with a CVI Melles Griot guarantee of performance.



Beam delivery options including precision-focused spots, custom-tailored spot geometries, and fiber optic beam delivery maximize your installation and service options. Logistics and service arrangements including safety stock, kanban, rotating service spares, and global pricing and service help ensure that you have the right light sources in the right locations at the right time.

Select from more than 33 wavelengths

CVI Melles Griot manufactures a comprehensive line of lasers and laser systems for laboratory and OEM applications. Standard products include helium neon and helium cadmium lasers, diode-pumped solid-state lasers, argon, krypton, and mixed gas ion lasers, and semiconductor laser assemblies. Available wavelengths range from 325 nm in the ultraviolet to 1.55 μm in the near infrared, with powers ranging from a few milliwatts to several watts, as shown in the chart below.

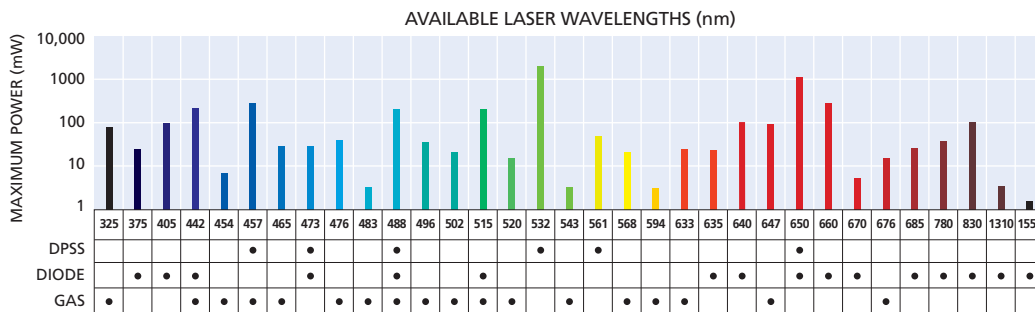

Lasers | Lenses | Mirrors | Filters | Assemblies | Windows | Shutters | Waveplates | Mounts

cvmellesgriot.com | Lasers +1 760 438 2131 | Optics & Photonics +1 505 296 9541 | Europe +31 316 333 041 | Asia +81 3 3407 3614