

REVISION HISTORY

ZONE	REV.	BY	DESCRIPTION	DATE	ECO	APPROVAL
	A		RELEASE FOR PRODUCTION			
	B	WJ	ADDED CATALOG MODEL TABLE	6/7/07	3236	

NOTES:

- 1.0 SPECIFICATIONS:
  - 1.1 MAXIMUM APERTURE: 34.9mm
  - 1.2 WIRE LENGTH: 3.0 [76.2]
  - 1.3 NUMBER OF SHUTTER BLADES: 5
- 2.0 DIMENSIONS ARE IN: INCH [MILLIMETERS]
- 3.0 AVAILABLE SOLENOID VOLTAGES: SEE CHART

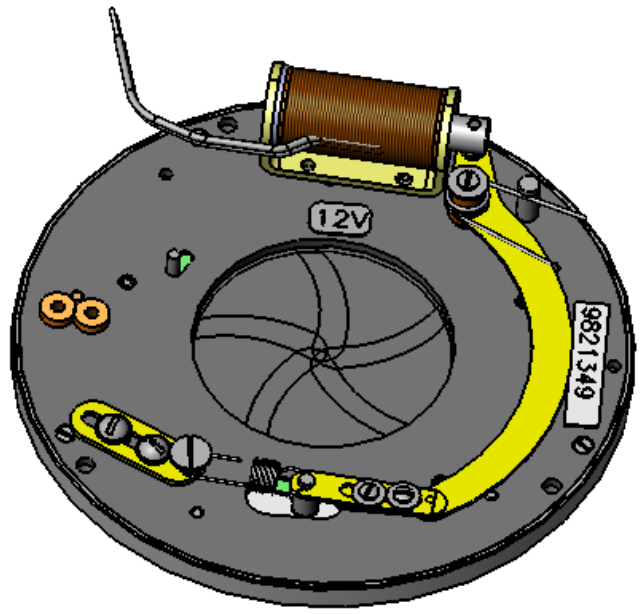
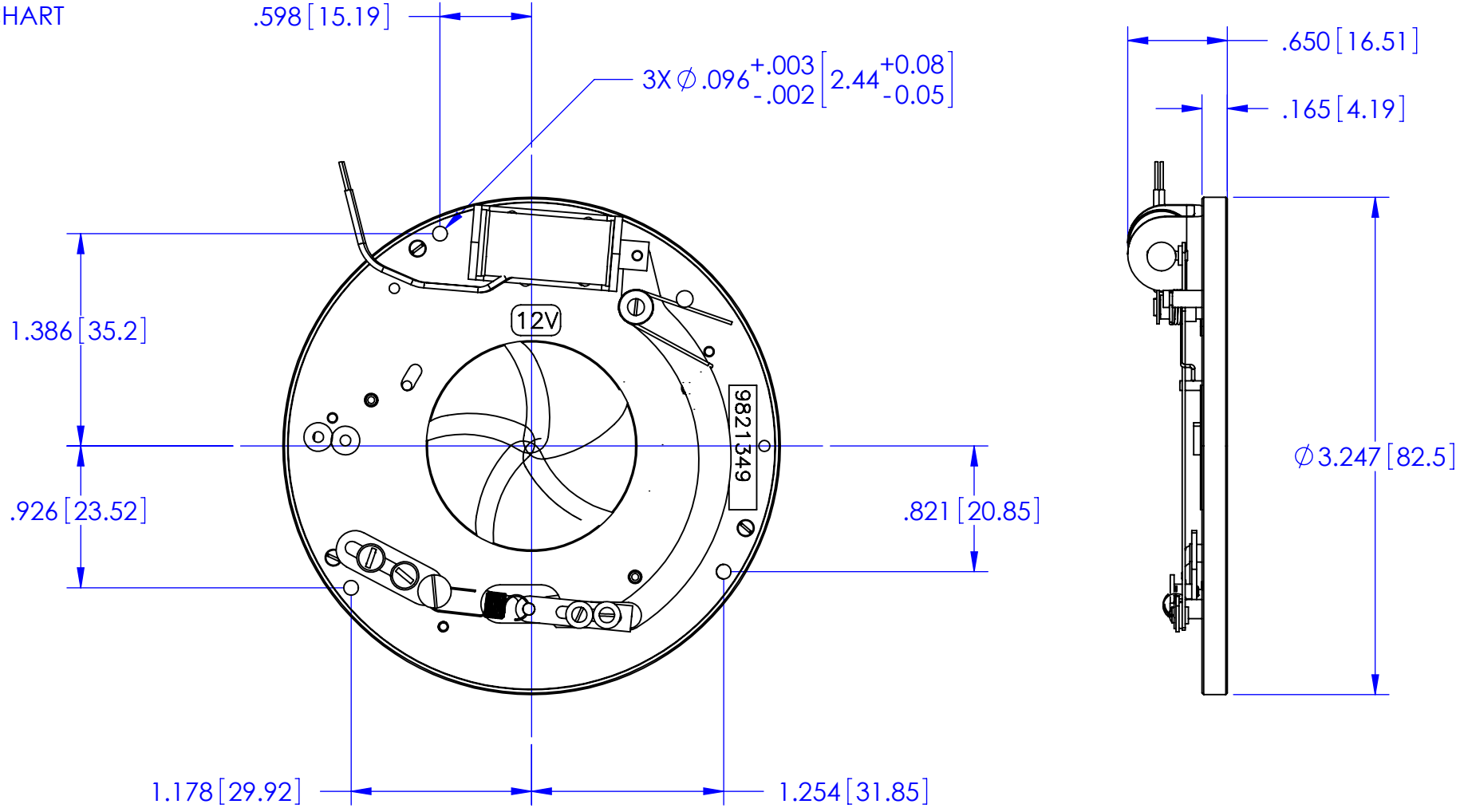

04UTS232	48 VOLT SHUTTER
04UTS230	24 VOLT SHUTTER
04UTS228	12VOLT SHUTTER
04UTS226	6 VOLT SHUTTER
PRODUCT NUMBER	DESCRIPTION

INTERPRET DIMENSIONS AND TOLERANCES PER ASME Y14.5M-1994	MATERIAL:
<b>DO NOT SCALE DRAWING</b>	CHEM. FINISH:
THIRD ANGLE PROJECTION	DRAWN BY: W JOHNSON DATE: 9/27/99 APPROVAL:

**CVI Melles Griot**  
55 SCIENCE PARKWAY, ROCHESTER, N.Y. 14620

TITLE: **SYSTEM DRAWING, SHUTTER, #3 ULTRA THIN (NC)**

SIZE	DWG. NO.	REV.	P NO.
B	24350-S	B	

SCALE: 1:2 J:\ SHEET 1 OF 1

PROPRIETARY NOTICE: THIS DRAWING IS CONFIDENTIAL AND THE INFORMATION THEREON SHALL NOT BE COPIED NOR UTILIZED IN ANY WAY WITHOUT PERMISSION FROM CVI MELLES GRIOT ROCHESTER. DRAWING TO BE RETURNED UPON REQUEST.