

REVISION HISTORY						
ZONE	REV.	BY	DESCRIPTION	DATE	ECO	APPROVAL
	A	WJ	RELEASED FOR PRODUCTION	6/20/99		

NOTES:

- 1.0 SPECIFICATIONS:
 - 1.1 MAXIMUM APERTURE: 42.7mm
 - 1.2 CORD LENGTH: 9.0 [228]
 - 1.3 NUMBER OF SHUTTER BLADES: 5
- 2.0 DIMENSIONS ARE IN: INCHES[MILLIMETERS]
- 3.0 SOLENOID VOLTAGE: 12 VOLTS

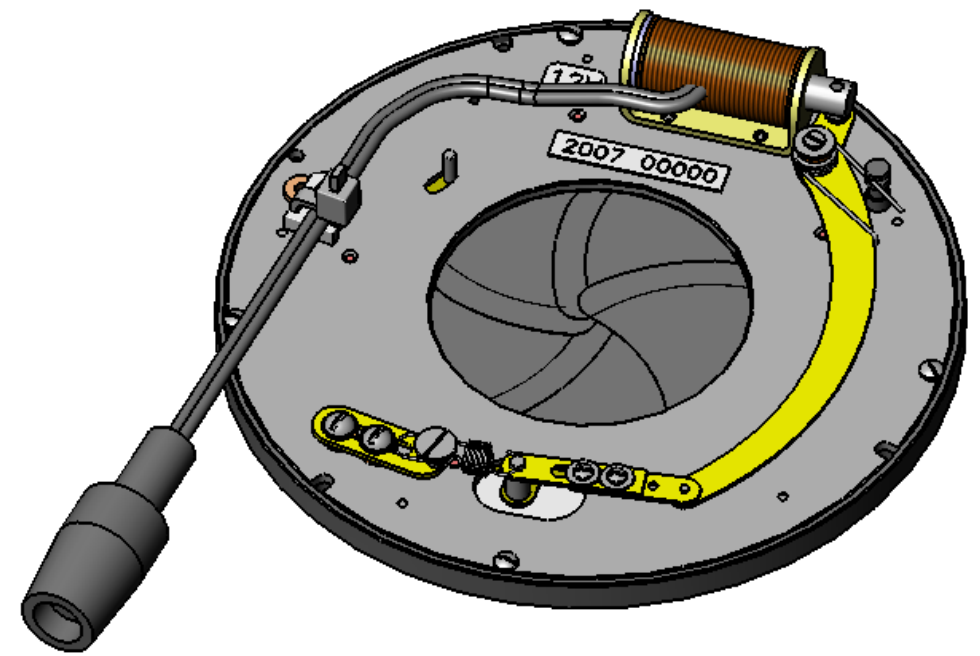
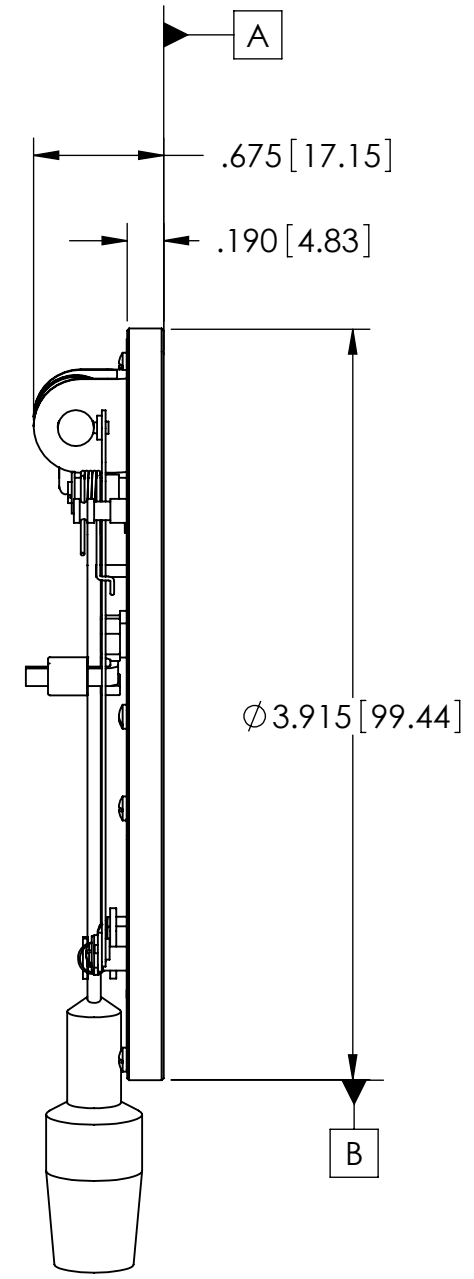
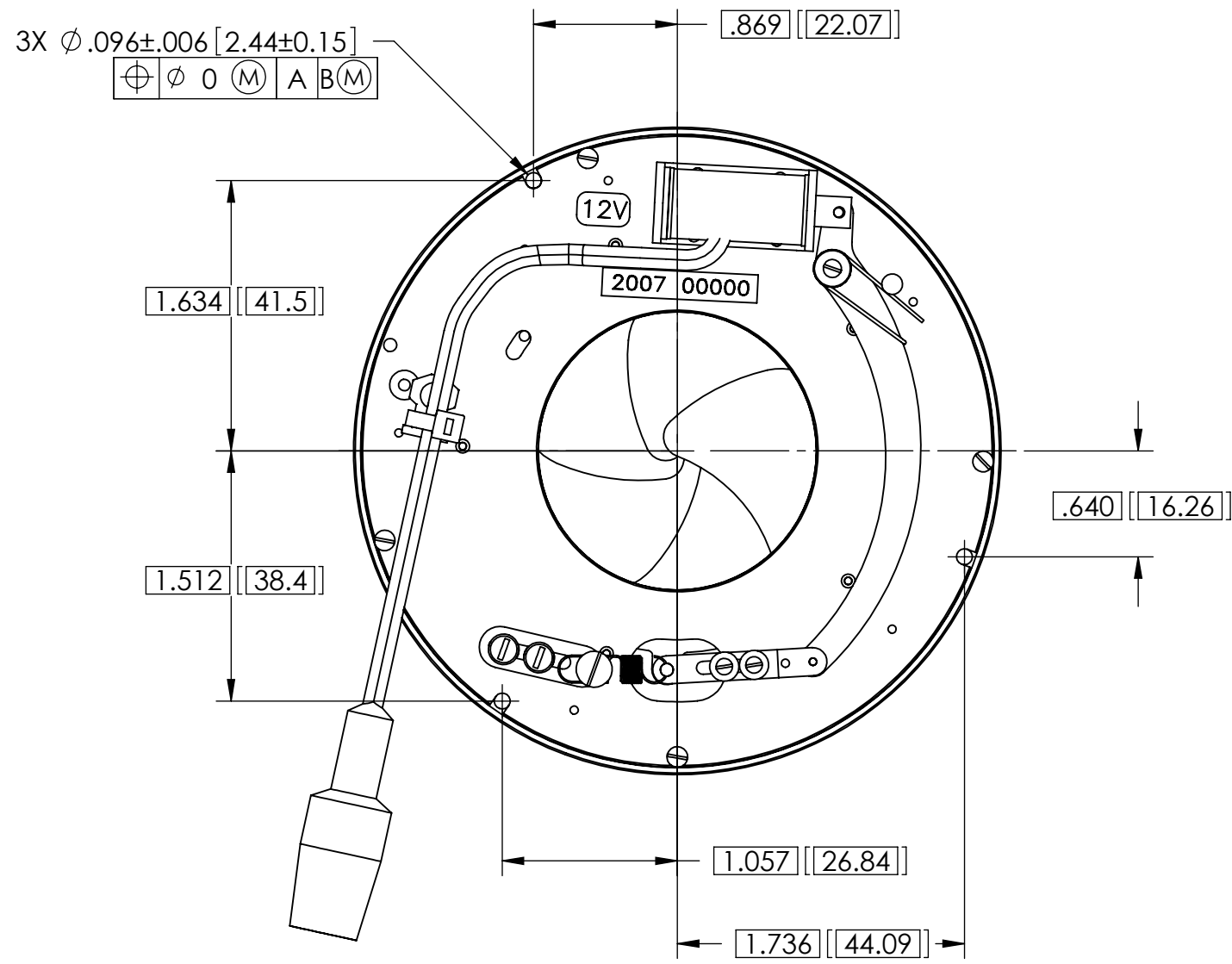

PRODUCT NUMBER: 04UTS204

INTERPRET DIMENSIONS AND TOLERANCES PER ASME Y14.5M-1994	MATERIAL:
DO NOT SCALE DRAWING	CHEM. FINISH:
THIRD ANGLE PROJECTION	DRAWN BY: W JOHNSON DATE: 8/20/99 APPROVAL:
PROPRIETARY NOTICE: THIS DRAWING IS CONFIDENTIAL AND THE INFORMATION THEREON SHALL NOT BE COPIED NOR UTILIZED IN ANY WAY WITHOUT PERMISSION FROM CVI MELLES GRIOT ROCHESTER. DRAWING TO BE RETURNED UPON REQUEST.	

CVI Melles Griot
 55 SCIENCE PARKWAY, ROCHESTER, N.Y. 14620

TITLE: SYSTEM DRAWING, #4 ULTRA THIN SHUTTER
 12 VOLT, (NC), W/CONTROLLER CONNECTOR

SIZE	DWG. NO.	REV.	P NO.
B	24220-S	A	

SCALE: 1:1 SHEET 1 OF 1