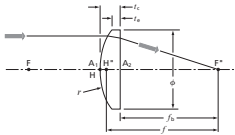
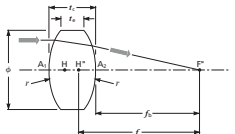
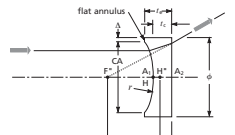
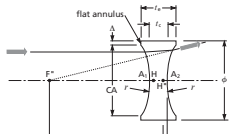
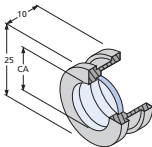
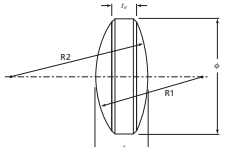
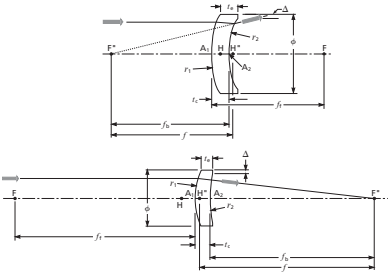
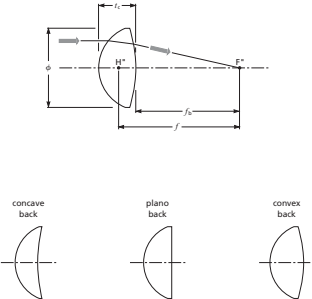
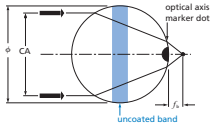
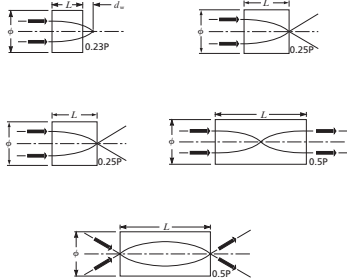

# Spherical Lenses

## Selection Guide

Product Type	Description	Page
<b>Plano-Convex Spherical Lenses</b> LPX, PLCX, LUP, PXS	 <p>Plano-convex lenses have one flat and one convex surface. They have a positive focal length and, when the preferred focal plane is adjacent to the flat surface, they closely approach best-form for infinite and near-infinite conjugate ratios.</p>	4.3
<b>Bi-Convex Spherical Lenses</b> LDX, BICX, LUD	 <p>Bi-convex or symmetric-convex lenses have two convex surfaces with identical radii. They are recommended for virtual imaging of real objects and for positive conjugate ratios from approximately 0.2 to 5 (values are wavelength sensitive). Due to the symmetry, aberrations such as coma, distortion, and chromatic aberration almost exactly cancel out at unit conjugate ratio. Aberrations increase as conjugate ratios depart from unity.</p>	4.24
<b>Plano-Concave Spherical Lenses</b> LPK, PLCC, LUK	 <p>Plano-concave lenses have one flat and one concave surface. They have a negative focal length and are often used to expand light or to increase focal lengths in optical systems.</p>	4.35
<b>Bi-Concave Spherical Lenses</b> LDK, BICC, LUB	 <p>Bi-concave or symmetric-concave lenses have a negative focal length and two concave surfaces with identical radii. Symmetric-concave lenses can be found in laser beam expanders, optical character readers, viewers, and projection systems.</p>	4.45
<b>Lens Kits</b> KLS, LK	 <p>Lens kits are available for standard and laser-quality lenses. Uncoated, coated, unmounted and mounted versions are offered.</p>	4.51
<b>Positive Bestform Lenses</b> BFPL	 <p>Bestform lenses are bi-convex lenses designed and manufactured to minimize coma and spherical aberrations. Positive bestform lenses are of exceptional performance and provide the smallest spot size available in a singlet lens.</p>	4.54

Selection Guide (continued)

Product Type	Description	Page
<p><b>Meniscus Lenses</b> MENN, MENP</p> 	<p>Meniscus lenses have one convex and one concave surface. They are used to change the focal length of another lens. They can change the effective f-number. The lens shape does not introduce additional spherical aberration or coma into the system.</p>	4.56
<p><b>Aspheric Glass Condenser Lenses</b> LAG</p> 	<p>Aspheric lenses provide better performance by reducing aberrations. They are ideal for use in low f-number, high-throughput applications. These lenses have one aspheric surface. The second surface is flat, spherical-convex, or spherical-concave. A flat second surface minimizes aberration. A spherical-convex second surface provides the lowest f-number and highest transmission because equal deviation of marginal rays is most closely approached. The spherical-concave second surface provides greater clearance from the light source and accommodates forced-air cooling.</p>	4.61
<p><b>Ball Lenses for Diode Lasers</b> LMS</p> 	<p>Spherical ball lenses are ideal for fiber-to-fiber and diode laser-to-fiber coupling. They are easier to align than thin lenses and have greater coupling efficiency.</p>	4.64
<p><b>Gradient-Index Lenses</b> LGD, LGE, LGS, LGT</p> 	<p>Gradient-index (GRIN) lenses combine refraction at the plane end surfaces with continuous refraction within the rod. Made from SELFOC®, a radial gradient-index material, GRIN lenses are easy to use and are well suited to coupling the output of a diode laser into an optical fiber. Aberration correction can be achieved without complex multi-element systems or aspherics. Real images are formed at the lens surface.</p>	4.66